

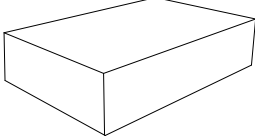















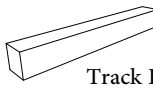

# Assembly Installation Inset

## Set Cabinet

	Item	Name			Parts	QTY	
 <p>Packing</p>		Tool Needed Screwdriver or Power Drill	2	 <p>Hardware Box</p>		Cam-lock Wheel	10
		A-1	1			4*16 MM Screw	32
		A-2	1			Cam-lock Post	10
		F B	1		4*30MM Screw	2	
		C	1	 <p>Track Box</p>		21 Inch Track	1 Pair
		D	1			Track Bracket	2
		E	1			Track Clip	2
		J	1				
			H	2			

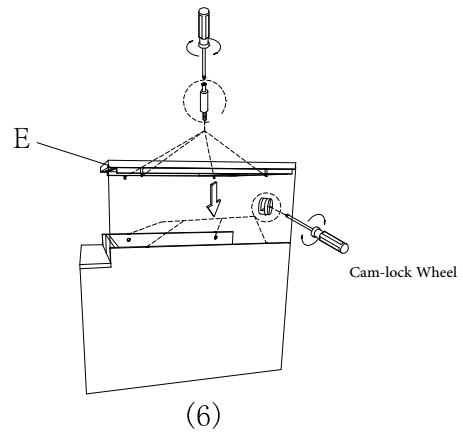
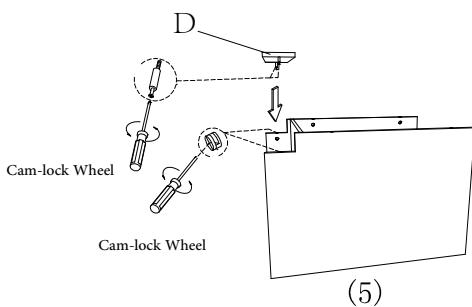
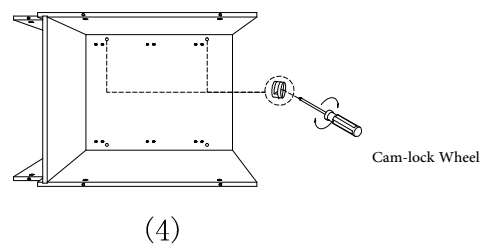
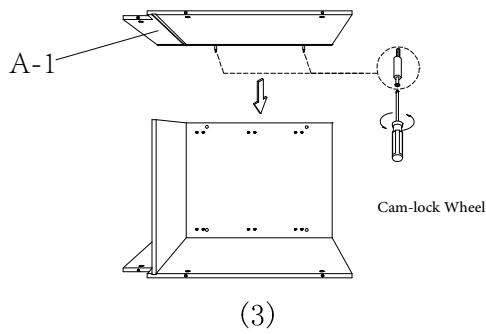
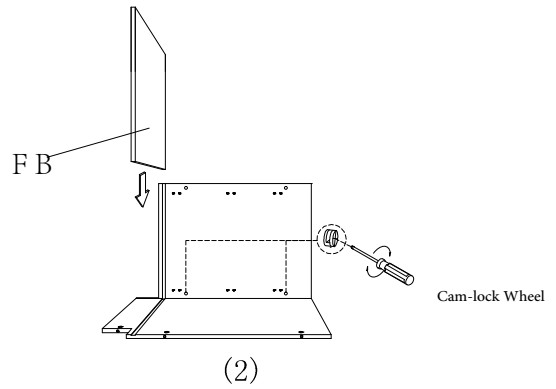
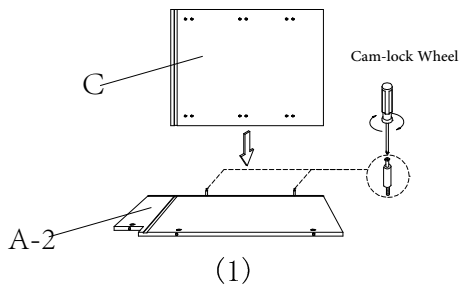

# Assembly Installation Inset

## Set Cabinet

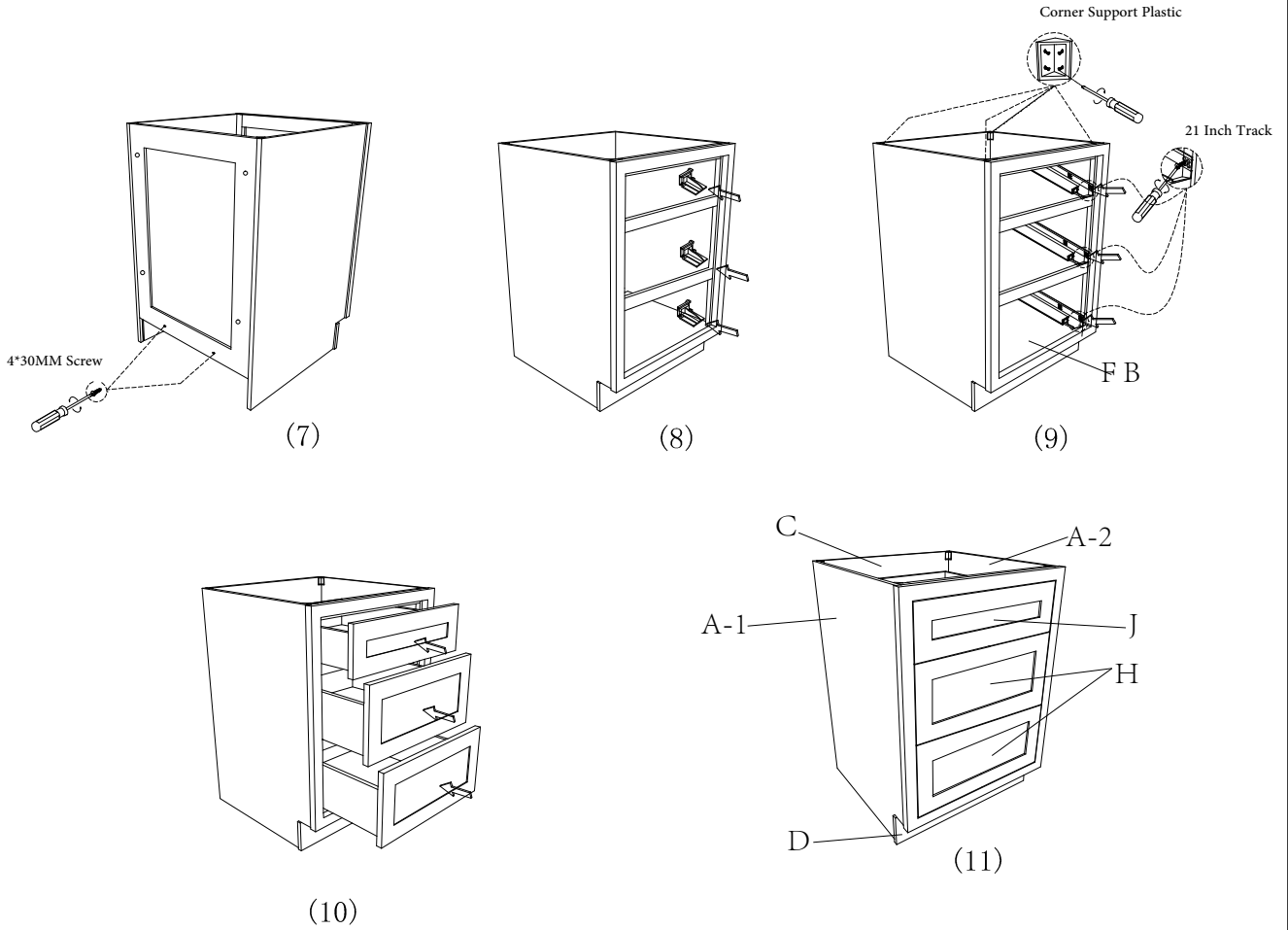

	Parts	QTY
	J-2	1
	J-3	1
	J-1	1
	J-4	1
	Track Clip	2

