

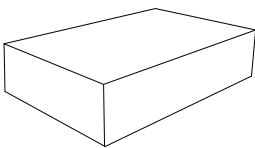









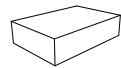





Assembly Installation

Inset Set Sink Base

	Item	Name	QTY			QTY	
 Packing		Tool Needed Screwdriver or Power Drill	2	 Hardware Box		Hinges	4
		A-1	1			Cam-lock Wheel	10
		A-2	1			4*16 MM Screw	32
		F B	1			Cam-lock Post	10
		C	1			4*30MM Screw	2
		D	1			Shelf Holder	4
		E	1				
		H	2				

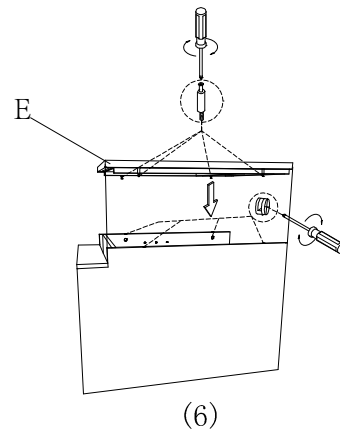
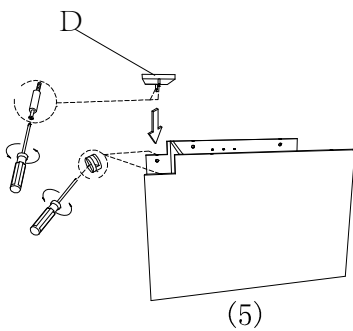
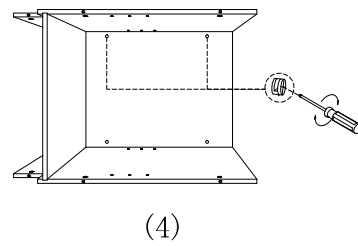
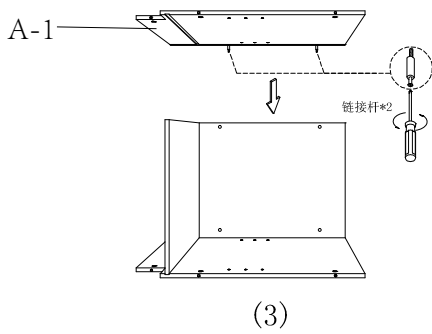
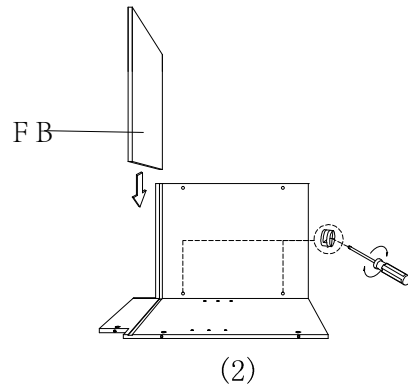
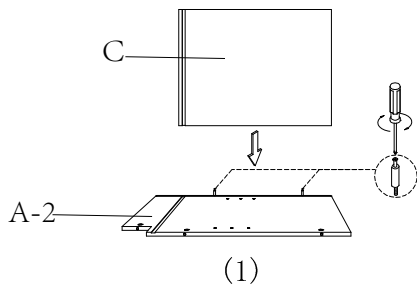

Assembly Installation

Inset Set Sink Base

